

Pentaflus Filtrazione S.r.l.

Via A. Moro, 18 20060 Pessano con Bornago (MI) - ITALY
 Tel: +39 02 36647850 Fax: + 39 02 36647851
 E-mail: pentaflus@pentaflus.com
 www.pentaflus.com

Electric self-cleaning screen filter FMA 1000 E

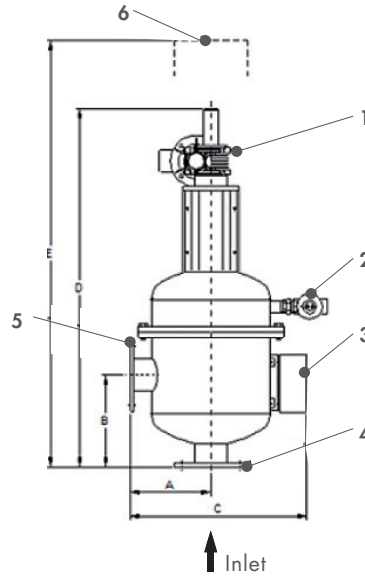

- 1 Electrical motor
- 2 Drain valve
- 3 Programmer
- 4 Inlet
- 5 Outlet
- 6 Maintenance area

Model	Dimensions (mm)					Filtering surface (cm ²)		Backwashing water consumption (l)		Weight (kg.)	
	A	B	C	D	E	PVC	ST.STEEL	PVC	ST.STEEL	PVC	ST.STEEL
FMA-1002-E	220	220	480	900	1150	910	1000	8	8	40	42
FMA-1003-E	220	250	480	980	1230	1600	1760	12,5	12,5	45	52
FMA-1004-E	260	320	590	1100	1340	2400	2650	15,5	15,5	60	67
FMA-1006-E	260	470	590	1375	1615	4800	5300	53	53	86	88

PVC Model	Flow rate (m ³ /h)			
	Max. flow rate	High Quality	Medium Quality	Low Quality
FMA-1002-E	50	30	20	10
FMA-1003-E	90	55	35	20
FMA-1004-E	150	75	55	30
FMA-1006-E	280	100	75	50

ST.STEEL Model	Flow rate (m ³ /h)			
	Max. flow rate	High Quality	Medium Quality	Low Quality
FMA-1002-E	70	35	25	10
FMA-1003-E	140	60	40	20
FMA-1004-E	200	80	60	30
FMA-1006-E	350	120	100	60

Note: Values for 125 microns. Other filtration degrees available on demand

